



CHEM-TECH

PULSAFEEDER



XP SERIES

The new **Chem-Tech XP Series** with peristaltic technology delivers worry-free dosing in a modern design. Each and every component of the **XP Series** is designed and manufactured for optimum reliability and durability for **REAL Performance**.

The electronic timing circuit in the adjustable 'A' Models provides **reliable** pump control, without relying on mechanical adjustment components that wear out over time.

The intuitive interface and controls provide **easy** operation and the peristaltic design is virtually maintenance-free.

Tailor-made for the water conditioning market, the **XP Series** offer **affordable** solutions in both initial cost and operation.

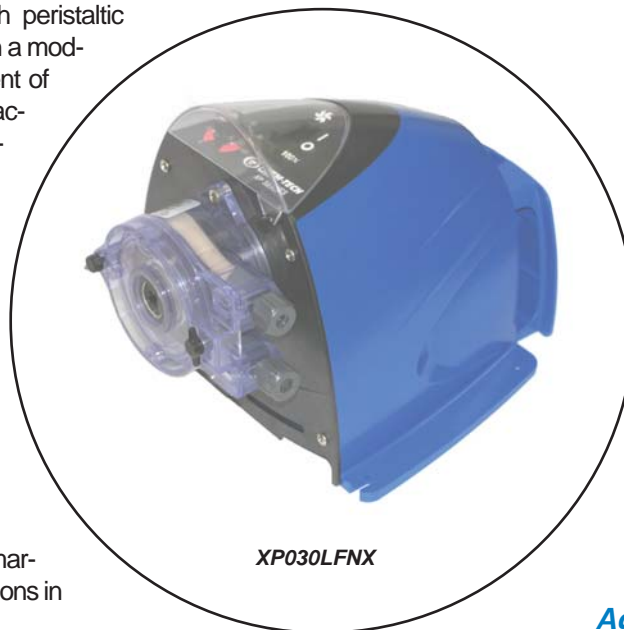

XP030LFNX

Easy tube change-out

Inherently Degassing

Extended Tube Life

Rugged Gear Train

Self Priming

Variable Speed (optional)

Adjustable Control (optional)

A rugged gear train and computer-aided peristaltic design ensure **long-lasting** performance.

Chem-Tech XP 60Hz Performance

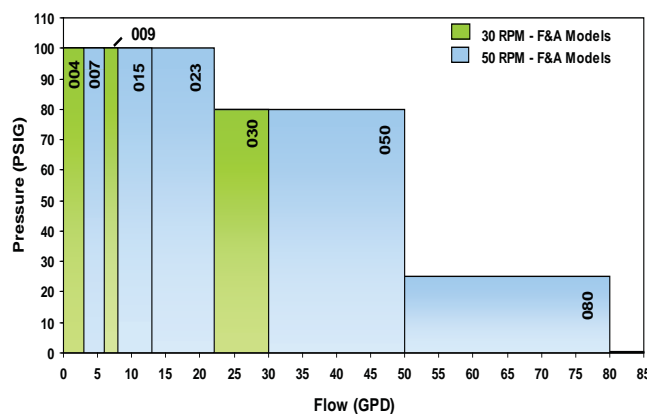

F Models – Simple and straight-forward fixed-rate pumps for applications where economy and ease-of-use are required. With 5 tube sizes to choose from, the F Models can deliver up to 80 USgpd and pressures up to 100 psi.

A Models – Built upon the solid F Model platform, the A Models incorporate an electronic timer module to provide a 20:1 turndown control for enhanced flexibility.

Chem-Tech XP Series Selection Guide

		X P _ _ _	_	_	N	_
MODELS:	XP004 = 4 GPD (0.6 LPH) @ 100 PSI (6.8 BAR) - 30 RPM XP007 = 7 GPD (1.1 LPH) @ 100 PSI (6.8 BAR) - 50 RPM XP009 = 9 GPD (1.4 LPH) @ 100 PSI (6.8 BAR) - 30 RPM XP015 = 15 GPD (2.4 LPH) @ 100 PSI (6.8 BAR) - 50 RPM XP023 = 23 GPD (3.6 LPH) @ 100 PSI (6.8 BAR) - 50 RPM XP030 = 30 GPD (4.7 LPH) @ 80 PSI (5.4 BAR) - 30 RPM XP050 = 50 GPD (7.9 LPH) @ 80 PSI (5.4 BAR) - 50 RPM XP080 = 80 GPD (12.6 LPH) @ 25 PSI (1.7 BAR) - 50 RPM					
ELECTRICAL:	L = 115V, 60Hz H = 230V, 60Hz 5 = 230V, 50Hz					
DRIVE:	F = Fixed Rate, On / Off Only A = Adjustable, On / Off with Current Interrupter Timer					
TUBING:	N = Standard Norprene with 1/4" NPT fittings					
SYSTEM	X = Pump Only 1 = 15 Gallon Tank System 3 = 35 Gallon Tank System T = 15 Gallon ITS System					

Example complete part number: XP030LFNT

Specifications	Optional
Max. Viscosity	300 Cps
Enclosure	NEMA 3R / IP31 (In Horizontal Position)
Temperature Limitations	125F / 51C max.
Electrical Requirements	1/6 HP / 30 RPM, 1/5 HP / 50 RPM, 115V / 60 Hz 230V / 60Hz or 230V / 50Hz
Shipping Weight	8 lbs. / 3.63kg.

* Specifications subject to change without notice

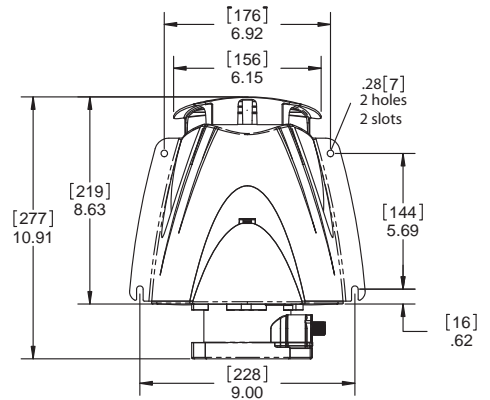
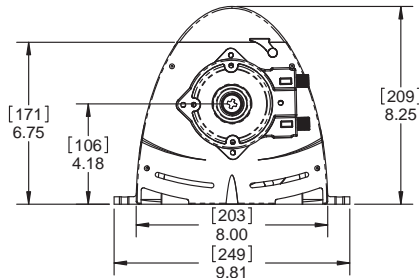
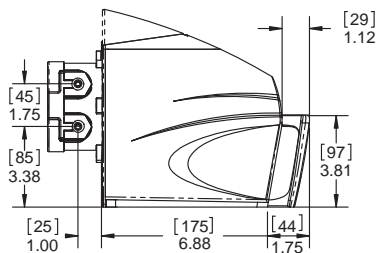

*All dimensions expressed as inches [mm]



An ISO Certified Company



CTI-009 B09

Standard Product Operations

27101 Airport Road • Punta Gorda, Florida 33982
 TEL (941) 575-3800 • TEL 800-333-6677
 FAX (941) 575-4085 • FAX 800-456-4085
 spotech@idexcorp.com • www.pulsafeeder.com